

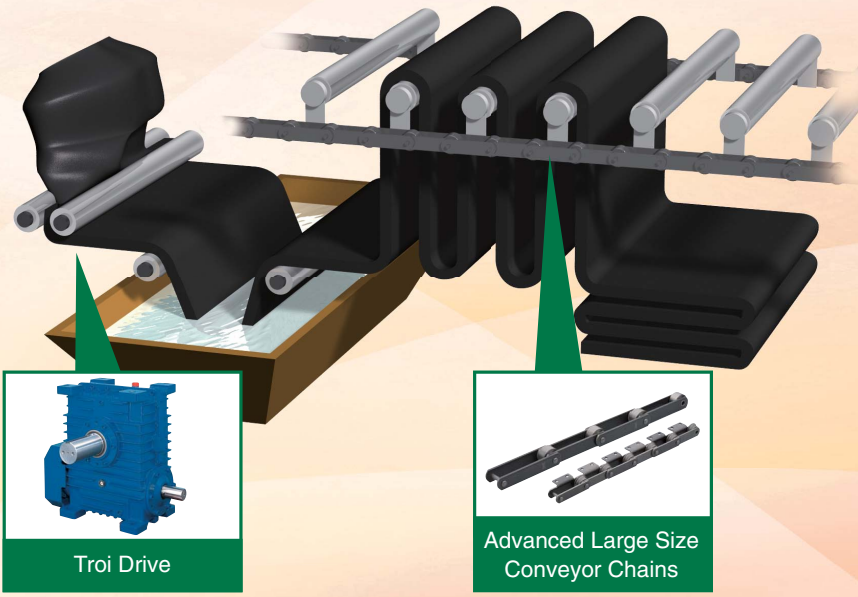

Tsubaki Power and Performance for the Tire Manufacturing Industry



Mixture (Smelting) Process



Component

Tread



Carcass

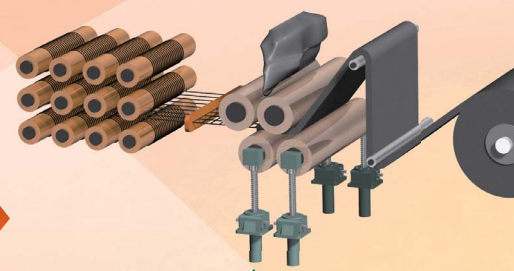

Bead

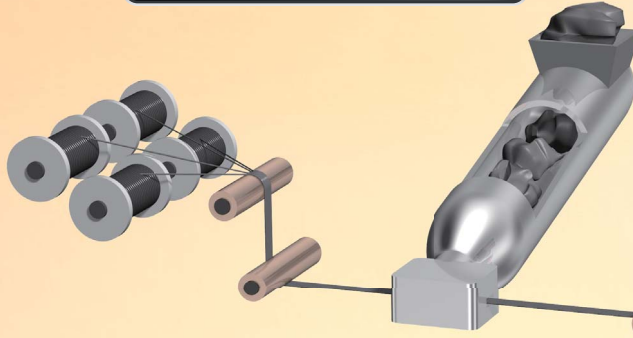

Tire component

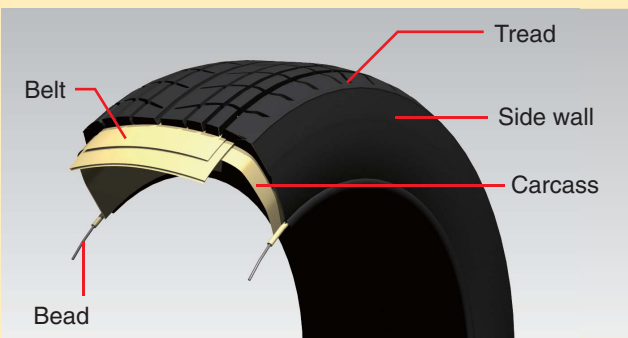

1 Tread

Contacts the road surface. The tread pattern is carved in order to discharge water and to prevent slipping.

2 Carcass

Cord layer coated with rubber to form the body of the tire. Its role is to endure load, shock, and air pressure.

3 Bead

Bundle of high-carbon steel. Its role is to fix both ends of the carcass and to fix the tire to the wheel.

4 Belt

Steel cords are mainly used, and their role in radial tires is to tighten the carcass and improve the rigidity of the tread.

5 Side wall

The tire deflects the most here, and its role is to endure shock and centrifugal force, and to protect the carcass.

nt Process

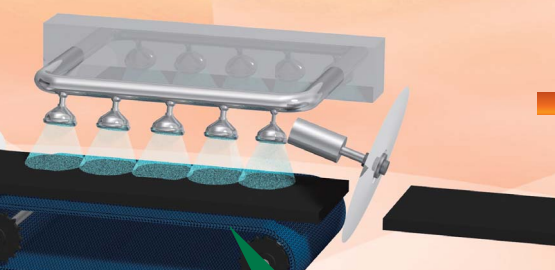

Plastic Modular Chain WT2706-K

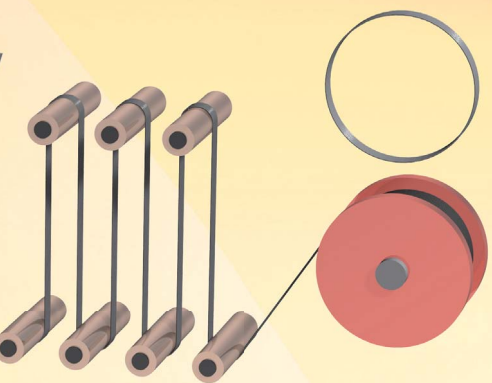
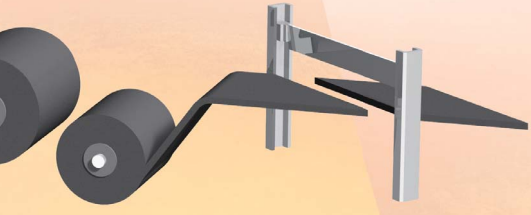

Forming Process

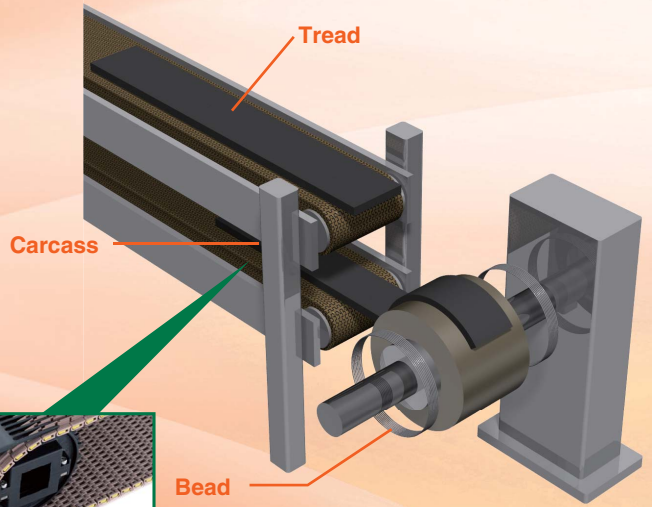

Plastic Modular Chain Raised rib type WT1907-K

Vulcanization Process

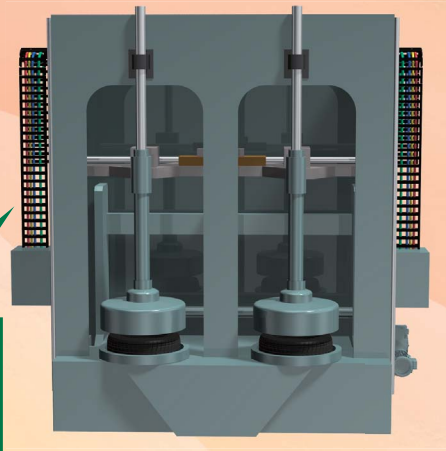

TKA Series Plastic CABLEVEYOR®

Verification Process

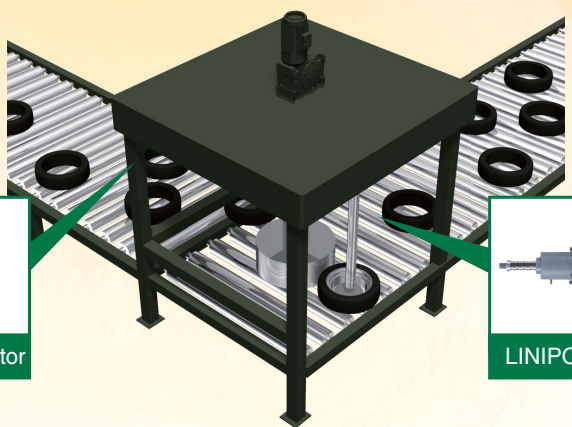

Small-Size Gear Motor



LINIPOWER® JACK



Mixture (Smelting) Process

A releasing agent is applied in order to prevent adhesion between sheets when manufacturing rubber sheets by blending the raw materials (natural rubber, synthetic rubber, carbon black, and sulfur).

Longer life

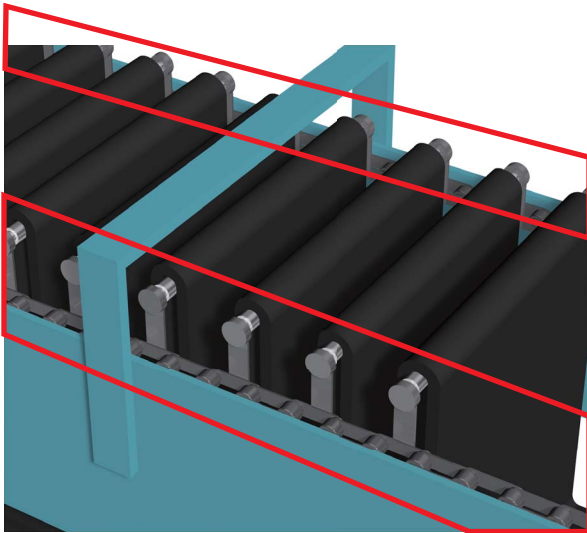

Batch off machine

Rubber sheet with releasing agent applied is dried using large size conveyor chains with bars attached.

Batch off machines Large Size Conveyor Chains

Various line-ups are available to meet customer needs for longer life under harsh environments with water, chemical, and abrasive substances.

Advanced models with improved wear resistance and allowable load have been newly added.

(Applications)

Wear resistance of roller improved over the DT Series

...AT Series, DTA Series, ATA Series, and more

Anti-rust action better than DT Series

...RT Series, YT Series, and more

Wear resistance between bush and roller



In-house comparison

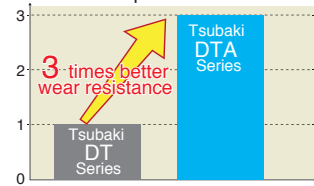

Longer life

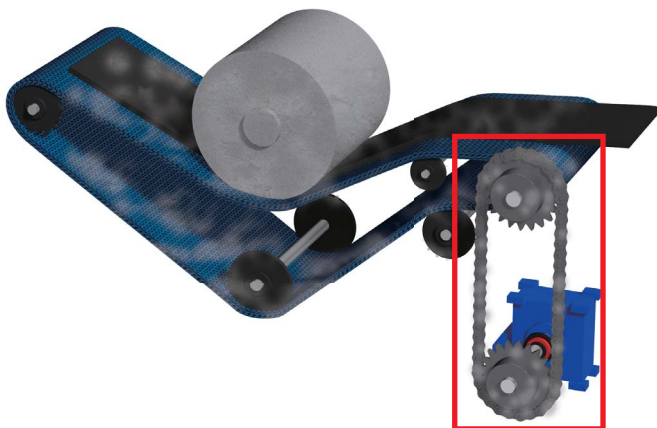

Drives and guides for various conveyors

Drive chain with corrosion resistance is used for drives for conveying sheets due to the presence of water and releasing agent.

Conveyor drives and guides Corrosion Resistant Drive Chains

Various types of drive chains are offered for applications in corrosive atmospheres with water and chemicals.

(Applications)

Stainless Steel Drive Chain (SS Series, AS Series)

AS Series: Recommended for longer life in atmospheres with spraying releasing agent.

Surface Treated Drive Chain (NP Series, NEP Series)

NEP Series: Recommended for longer life in atmospheres with water present.



Surface Treated Drive Chain

Internal salt water spray test result





Mixture (Smelting) Process

Energy savings & simpler equipment

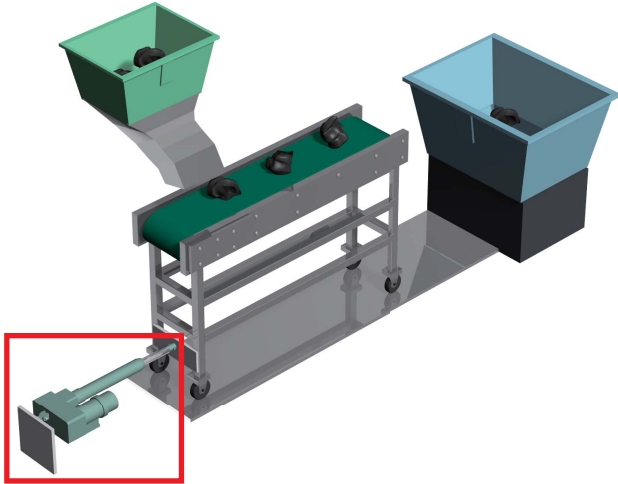

Component feeder

Rubber components are fed to the mixers and the extruders by conveyors and trolleys

Component feeders Power Cylinders

Electric linear actuator with good power savings. Power Cylinders with no power consumption during stand-by have higher power savings compared to hydraulic types that use pumps, and pneumatic types that drive compressors full time. Just simple electric wiring enables their use for various applications. They are used in traversing conveyors and trolleys, as well as opening/closing hopper bottom covers.



LCA assessment of Power Cylinders

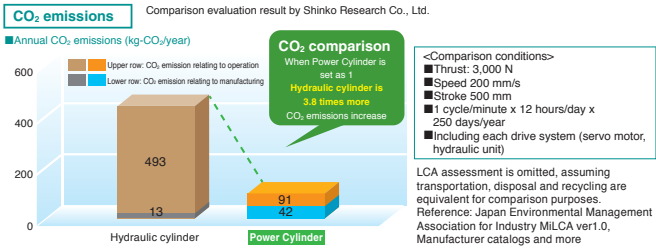

High power & compact

Rubber sheet extruders Troil Drive

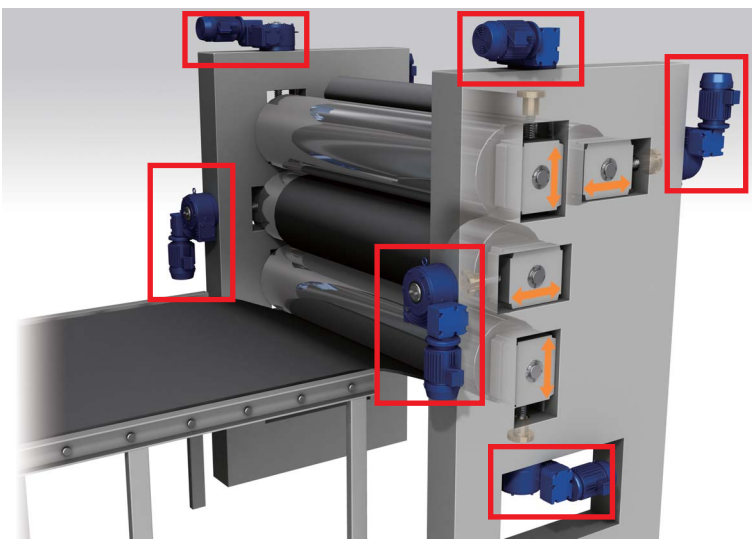

Calender roll

The kneaded rubber material is extruded through the rolling roll into a sheet.

This gear reducer uses the drum-shaped Troidal worm gear to achieve high transfer capacity and high efficiency. Trapezoidal screws are also used, making it possible to adjust the clearance between the rolls. Meanwhile, minimal uneven rotation helps to improve roller positioning accuracy. Load repulsion is also limited through self-locking capabilities, thereby reducing potential motor problems.

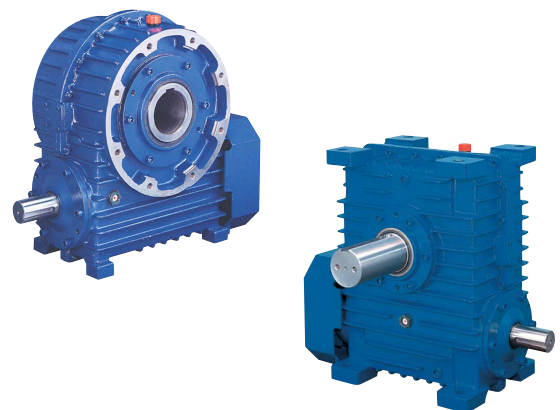



Component Process

Rubber sheets manufactured in the mixture (smelting) process are processed into components that form the tire, such as the tread and carcass.

(Tread) The component that is in contact with the road surface and is processed to the most suitable thickness and shape.

(Carcass) The component that forms body of the tire, it is a sheet with a cord layer that is coated with rubber.

(Bead) Bundles of piano wires, which are useful for fixing the carcass, or fixing it to the wheel.

Clean & easy to maintenance

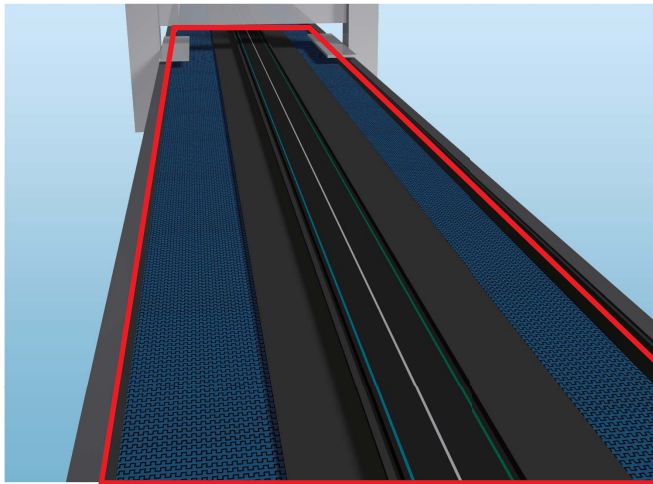

Tread cooler conveyor

Treads, a component of tires, are hot after the rolling process and are cooled to normal temperature by immersion in water.

Tread cooler conveyors Plastic Modular Chain WT2706-K

All-plastic chain with excellent water-repellent and anti-rust properties is recommended for this process, which uses a lot of water for cooling.

It is light weight and easy to maintain. In addition, the connecting pins are covered with links, preventing unexpected connecting pin breakage.

(WT2706-K overview)

- Chain pitch: 27.2 mm Link height: 8.7 mm
- Just a single screwdriver is required for cutting and connecting, allowing sectional replacement
- Plastic plugs that are detectable with metal detectors are also available



Maintain thrust & stopping accuracy

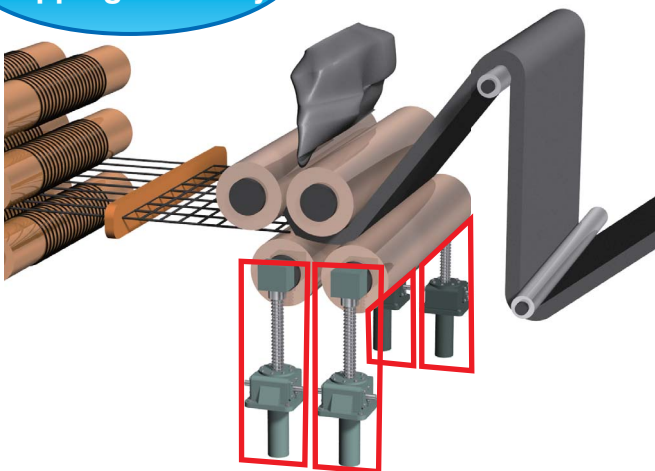

Calender roll

The rubber sheet rolled in the previous process is crimped onto the cord layer to roll into a thin sheet with a certain thickness again.

Calender rolls LINIPOWER® JACK

Lini Power Jacks with trapezoidal screws are recommended in this process, in which rubber is rolled to a certain thickness. Using the motor together with the brake enables stable positioning, load maintenance, and power savings.

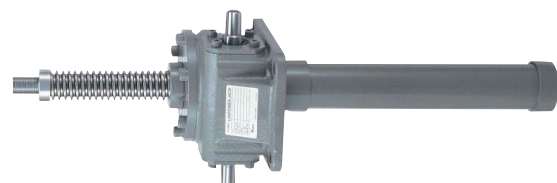



Forming Process

Components such as tread, carcass, and bead that make up the tire are accumulated, wound, and affixed to the drum to be formed into the shape of the tire. The tire formed in this process is soft, and is called a raw tire (green tire).



Zero roll-in

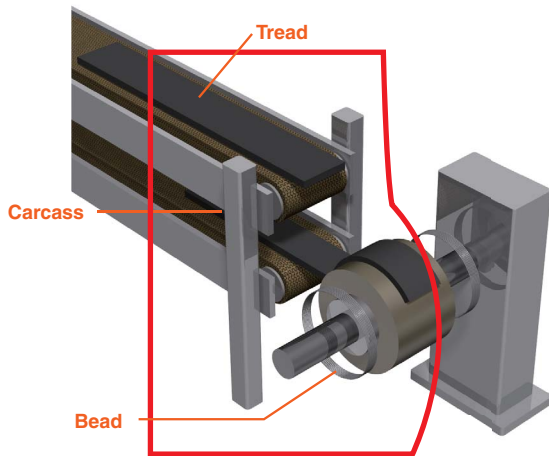

Component feeders Plastic Modular Chain Raised rib type WT1907-K

The gap at the junction is reduced to zero by combining with plates in a comb shape similar to that of escalators. This prevents roll-in of the end of rubber sheets. (WT1907-K overview)

- Chain pitch: 19.05 mm Link height: 14.3 mm
- Parts are all made of plastic for lighter weight
- Just a single screwdriver is required for cutting and connecting, allowing sectional replacement



Component feeder (cut process)

Components in sheet shape are cut and automatically fed to the drum that forms the tire.

Speed stability & quietness

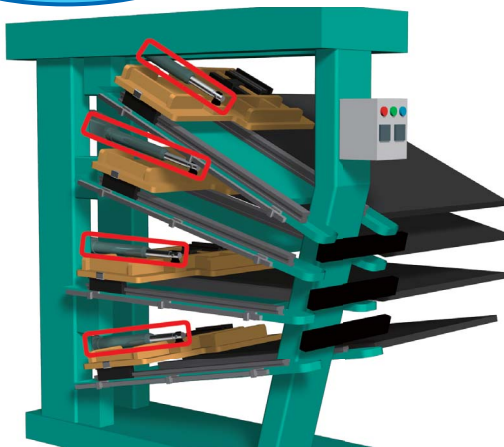

Component feeders Power Cylinders

Electrically-driven cylinders using ball screws and trapezoidal screws.

Most suitable for applications with high-speed and high-frequency operation.

This has excellent quietness, and is capable of operating with stable speed thanks to its design using an induction motor to turn the screws and move the rod forward and backward.



Component feeder (end)

The table that feeds the cut components to the drum to form the tire telescopes.



Vulcanization Process

The tire is finished with excellent strength and elasticity by injecting, heating, and pressurizing (vulcanizing) the raw tire (green tire) manufactured in the forming process into the mold. This process applies grooves (tread pattern) on the tread portion that comes into contact with the ground.

Reliable cable protection

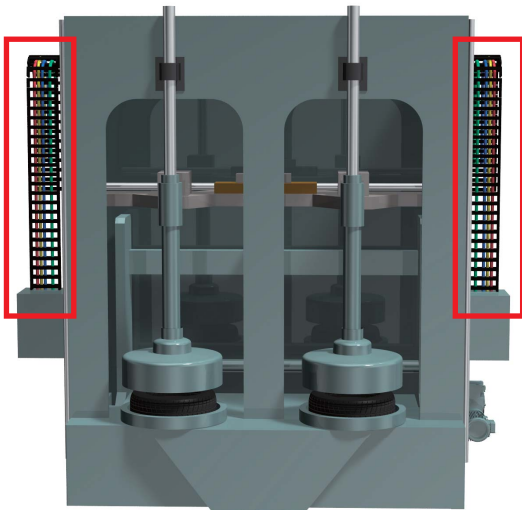

Vulcanizer

The raw tire (green tire) is injected into the mold, onto which tread patterns and stampings are applied through heat and pressure.

Vulcanizers CABLEVEYOR®

Electric cables are routed through the body to ensure the support and guidance of cables between moving devices and fixed ends.

Various types of products are available, including compact and large sizes, open types (TKP), and closed types (TKC, TKA).

The closed type is recommended for protecting cables in the harsh atmosphere around vulcanizers.



TKP



TKA

Efficient use of space

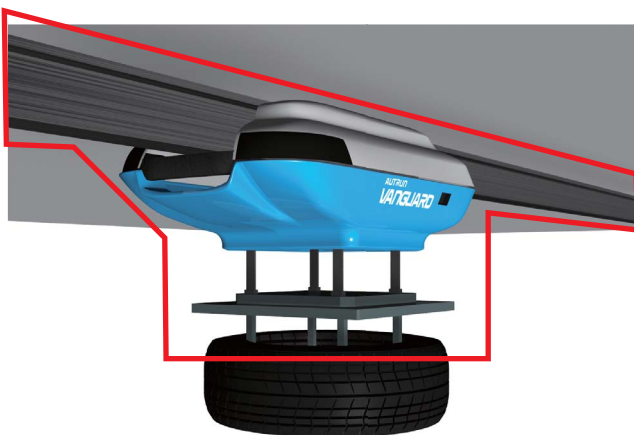

Ceiling monorail conveying device that conveys between the forming and vulcanizing processes

Ceiling conveyor equipment AUTRAN VANGUARD

This device enables efficient use of space and high speed conveying by traveling along the ceiling. It uses a non contact power supply as well to improve reliability.

Tires from 13 to 20 inches can be conveyed.

A gripper with a diameter smaller than the outer diameter of the tire is used, which enables simple and neat layouts.





Verification Process

Scratches, distortions, and more are checked in the verification process.

Balance, uniformity, and more are verified by equipment, so only tires that pass are shipped out.

Wide variety

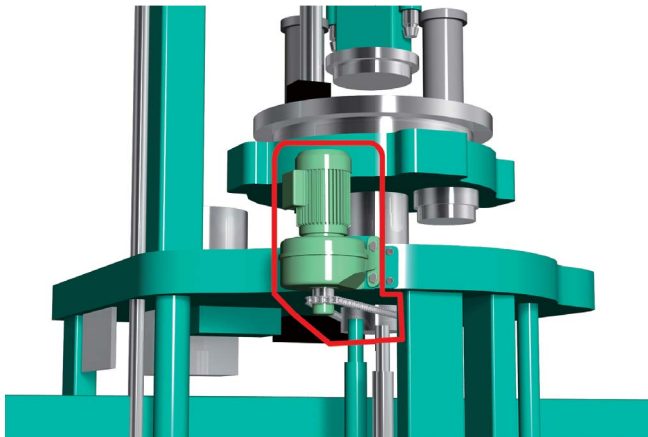

Balancing machine

Balance of the axle is measured using centrifugal force by rotating the tire.

Balancing machines Small-Size Gear Motors

Various series including Gear Motors, Hypoid Motors, and Croise Motors are available to offer selection to match with the installation space.

They also comply with efficiency regulations for motors that are becoming drastically restrictive all over the world. These are new generation small-size gear motors with superior power savings and performance.

(Complies with high-efficiency regulations in Japan, North America, China, Korea, and Europe)

(Gear Motors) Light weight and compact size are achieved by using a helical gear.

Motor 40 W to 5.5 kW, reduction ratio 1/5 to 1/1200

(Hypoid Motors) Space saving is achieved by using a hollow shaft. Motor 40 W to 5.5 kW, reduction ratio 1/5 to 1/1200

(Croise Motors) Using a worm gear realizes superior shock resistance and quietness.

Motor 0.1 kW to 3.7 kW, reduction ratio 1/10 to 1/300



High efficiency

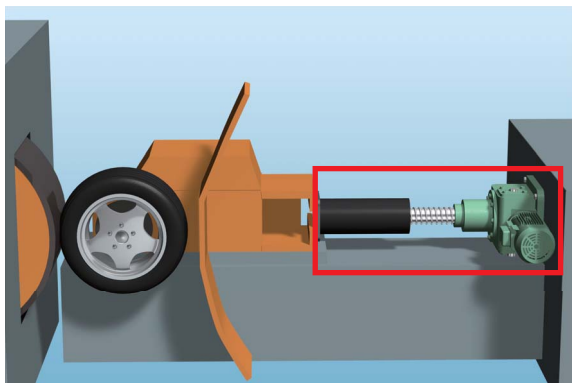

Uniformity machine

Equipment to measure uniformity during tire travel by turning a fixed tire and pressing a drum.

Uniformity machines LINIPOWER® JACK

High-performance jack combining ball screws and trapezoidal screws with high precision worm gears. The ball-screw-type is used in uniformity machines. It is suitable for high-speed and high-frequency applications, and realizes large thrust (force to press drum) with a small drive source.

(Basic capacity)

- 0.5 kN to 100 kN



G8 Series Drive Chain

Drive Chain & Sprocket

RS Roller Chain



Lube-Free Lambda Drive Chain



Corrosion-Resistant Surface Treated Neptune Chain®



Evolving chain wear life

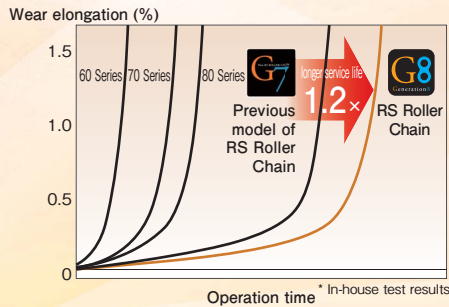

These lube-free chains employ our special, oil-impregnated bushes for a long service life. Environmentally friendly NSF H1 certified oil is used for impregnating. This reduces maintenance man-hours and keeps the environment clean.

This chemical-resistant chain stands up to corrosive or alkaline chemicals thanks to its special surface treatment. It retains its strength and easily replaces steel chains. RoHS compliant.

Plastic Modular Chain

Plastic Modular Chain consists of plastic parts only. It can convey anything from light components to heavy vehicles, and realizes reliable drive even with a belt sized conveying surface. It also allows any person to easily replace parts (maintenance), and is also easy to handle thanks to its light weight.

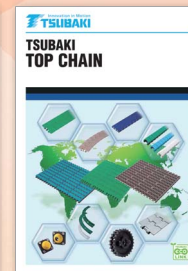

Large Size Conveyor Chains

Large size conveyor chain most suitable for conveying heavy objects. Our long experience allows a line-up of various specifications to provide solutions to customer problems. Large size conveyor chain is called "Smart Conveyor Chain®", under the concept of offering the best chain for the customer's application.



CABLEVEYOR®

Various series are available to meet customer needs including: TKP standard-type for general purposes, TKC closed-type, TKA type with excellent protection of cables from dust, and TK high-strength type made of steel. In addition, cables for movement are also available. Consider using them as well.

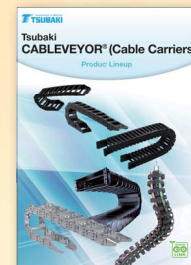

Power Cylinder & LINIPOWER® JACK

LINIPOWER® JACK

Jack combining ball screws/trapezoidal screws with high precision worm gears.

Power Cylinder

Electrically driven cylinder integrating ball screws/trapezoidal screws with a motor.

Power Cylinder vs. hydraulic, pneumatic cylinder

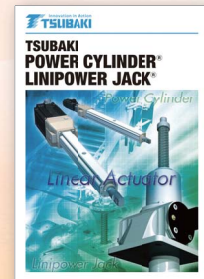
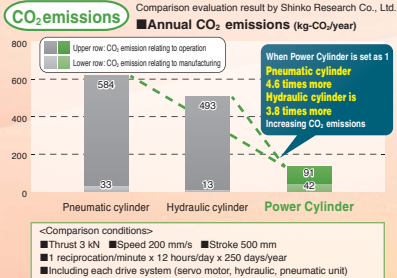

Electric drive is recommended for Power Cylinder & LINIPOWER® JACK



Eco & clean

Electric power savings are higher than with hydraulic or pneumatic types, and CO₂ emissions are also reduced. In addition, this product has no piping, which eliminates oil and air leakage from connections.



Secure holding of heavy loads is possible

Basic configuration has a motor with a brake mounted. Secure holding of heavy loads is enabled at any desired position, even when power is lost.



Simple layout

Operation is enabled just by connecting a power source. No large scale equipment or work is required, such as hydraulic pumps and compressor piping.



Accurate speed and position control is possible

Electric control of each motor enables discrete speed change. In addition, accurate position control and multiple point positioning are possible.

Small-Size Gear Motor

Gear Motor with the advantages of helical, hypoid, or worm gears.

- Gear Motor
Parallel shaft type helical geared motors. Helical gears provide high efficiency and low noise. Small, lightweight, and compact
- Hypoid Motor
Right-angle geared motors. Hypoid gear provides high efficiency. Low-profile compact body. Line-up of hollow and solid shafts.
- Croise Motor
Right-angle worm-gear motors. Self-locking properties, quiet operation and robust gear construction. High reduction ratio and helical gear combination achieves high-efficiency.



Troi Drive

High-performance worm gear enabling high transmission capacity and high efficiency.

- High-power and compact.
- Available in solid or hollow output types.
- Contributes to layout compactness.



TSUBAKIMOTO CHAIN CO.

Japan	Headquarters	+81 6-6441-0011	https://tsubakimoto.com
-------	--------------	-----------------	---

Global Group Companies

AMERICAS

United States of America	U.S. Tsubaki Power Transmission, LLC	+1 847-459-9500	https://www.ustsubaki.com/
Brazil	Tsubaki Brasil Equipamentos Industriais Ltda.	+55 11-3253-5656	http://tsubaki.ind.br/
Canada	Tsubaki of Canada Limited	+1 905-676-0400	http://tsubaki.ca/

EUROPE

Netherlands	Tsubakimoto Europe B.V.	+31 78-6204000	https://tsubaki.eu/
France	Kabelschlepp France S.A.R.L.	+33 1-34846365	https://kabelschlepp.fr/
Germany	Tsubaki Deutschland GmbH Tsubaki Kabelschlepp GmbH	+49 89 2000 133 80 +49 2762-4003-0	http://tsubaki.de/ https://tsubaki-kabelschlepp.com/
Italy	Kabelschlepp Italia S.R.L.	+39 0331-350962	https://kabelschlepp.it/
Russia	ООО Tsubaki Kabelschlepp	+7 499-4180212	http://kabelschlepp.ru/
Spain	Tsubaki Ibérica Power Transmission S.L.	+34 911-873450	http://tsubaki.es/
United Kingdom	Tsubakimoto U.K. Ltd.	+44 1623-688-700	https://tsubaki.eu/

INDIAN OCEAN RIM

Singapore	Tsubakimoto Singapore Pte. Ltd.	+65 6861-0422/3/4	http://tsubaki.sg/
Australia	Tsubaki Australia Pty. Limited	+61 2-9704-2500	http://tsubaki.com.au/
India	Tsubaki India Power Transmission Private Limited	+91 44-7101-2000	http://tsubaki.in/
Indonesia	PT. Tsubaki Indonesia Trading	+62 21-8945-8898	http://tsubakimoto.co.id/
Malaysia	Tsubaki Power Transmission (Malaysia) Sdn. Bhd.	+60 3-5888-8275	http://tsubaki.my/
New Zealand	Tsubaki Australia Pty. Limited - New Zealand Branch	+64 9 352-2085	http://tsubaki.com.au/
Philippines	Tsubakimoto Philippines Corporation	+63 2-808-0067	http://tsubaki.ph/
Thailand	Tsubakimoto (Thailand) Co., Ltd.	+66 2-262-0667/8/9	http://tsubaki.co.th/
Vietnam	Tsubakimoto Vietnam Co., Ltd.	+84 24-6274-1449	http://tsubaki.net.vn/

EAST ASIA

Korea	Tsubakimoto Korea Co., Ltd.	+82 2-2183-0311	http://tsubakimoto-tck.co.kr/
Taiwan	Taiwan Tsubakimoto Co.	+886 3-3293827	https://tsubakimoto.com.tw/

CHINA

China	Tsubakimoto Chain (Shanghai) Co., Ltd.	+86 215396-6651/2	http://tsubaki-sh.cn/
-------	--	-------------------	---